

# Atelier Haußmann 2021





“(...) It’s up to the product itself – its desire to be a bed, a hook or a table.”







8	HERRENBERGER	Stool
11	HERRENBERGER 500	Stool
13	PIOMBINO ALTO & BASSO	Table
22	LÁSZLÓ	Chair
24	SPRING	Stool
26	TISCH LEIPZIG	Table
28	AFFE	Trestle
30	LACKAFFE	Trestle
32	BOLOGNA	Table
34	PETITE TABLE D'ANGLE	Side table
37	BLUMENAMPEL	Object
37	BLUMENKUGEL	Object
39	BLUMENAMPEL EDITION	Object
39	BLUMENKUGEL EDITION	Object
41	RING	Wall-Object
43	YOUTOO	Wardrobe
45	HELLOGOODBYE	Wardrobe
47	POGGIBONSI	Shelf
49	2 PM DAYBED	Daybed
50	SEVENFEETUP	Bed



# HERRENBERGER

Stool  
by Atelier Haußmann





Seat shells:

Walnut transparently mat coated,  
beech black stained and transparently mat coated,  
oak transparently mat coated.

## HERRENBERGER

---

This stool is inspired by designs and models of 40s industrial furniture, characterized by strength and functionality. These attributes were applied to the HERRENBERGER, a simple, clear and timeless frame made of tubular steel standing secure and stable on 4 legs. The seat is made of solid turned wood with a shape that ensures the right comfort. Its simple appearance fits in almost everywhere.

---

### **Material**

#### **Seat shell:**

Hand turned beech seat shell, black stained and transparently coated, oak transparently mat coated or walnut transparently mat coated.

#### **Frame:**

Ø 20 steel tube frame, powdercoated (consisting of solvent-free polyester resin) or chromeplated, halfround PE glides (glides for different floors available on request).

Certified: DIN EN 16139:2014-03 (Testlevel L2)

### **Color**

Black glossy RAL 9005 (GL), black mat RAL 9005 (M), chrome (CR)  
Further RAL colors on request (min. 2 pieces)

### **Size**

Seat shell: Ø 33 cm

Three different sizes available:

#### **Art.-Nr. #650.1:**

H 65 x W 36 x D 36 cm, 5,9 kg

Packed:

H 68 x W 38 x D 38 cm, 7,5 kg

#### **Art.-Nr. #730.1:**

H 73 x W 39 x D 39 cm, 6,2 kg

Packed:

H 75 x W 42 x D 42 cm, 8 kg

#### **Art.-Nr. #810.1:**

H 81 x W 41 x D 41 cm, 6,4 kg

Packed:

H 85 x W 43 x D 43 cm, 8 kg

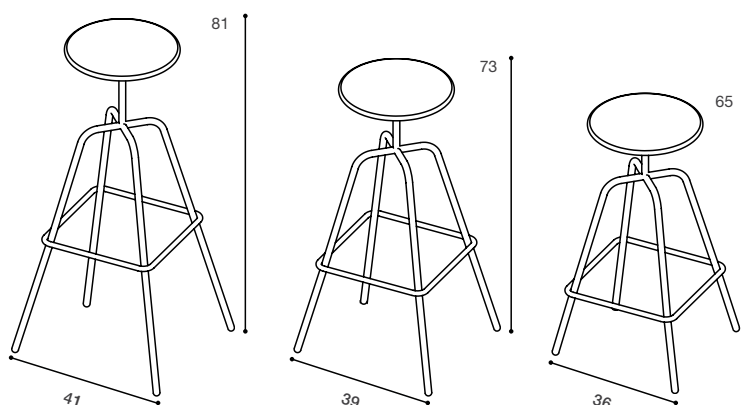



# HERRENBERGER

Stool  
by Atelier Haußmann

## HERRENBERGER

---

### **Material**

#### **Seat shell:**

Hand-turned beech black stained and transparently coated, oak mat transparently coated or walnut transparently mat coated.

#### **Frame:**

Ø 22 steel tube frame, powdercoated (consisting of solvent-free polyester resin), halfround PE glides (glides for different floors available on request).

### **Color**

Black glossy RAL 9005 (GL), black mat RAL 9005 (M), further RAL-colors on request (min. 2 pieces)

### **Size**

Seat shell: Ø 33 cm

#### **Art.-Nr. #500.1:**

H 50 x W 34 x D 34 cm, 3,8 kg

Packed:

H 54 x W 38 x D 38 cm, 5 kg

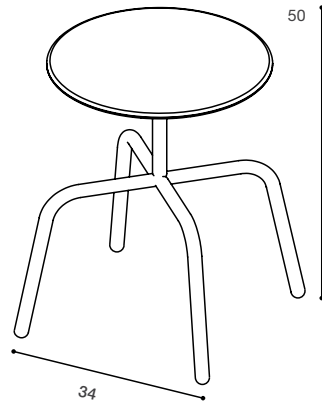

Atelier Haubmann

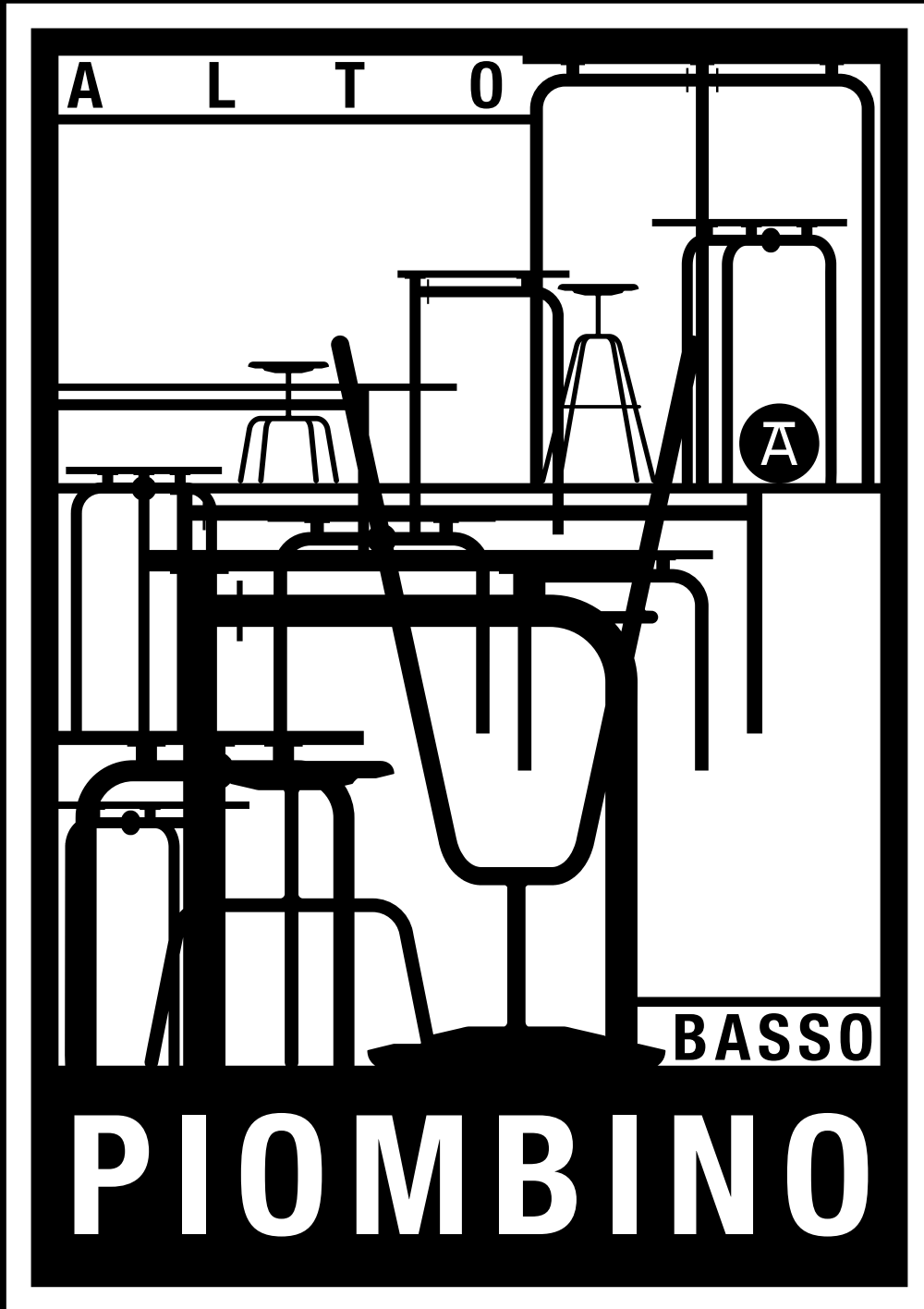

Piombino Alto / Piombino Basso © 2020

# PIOMBINO ALTO PIOMBINO BASSO

by Andreas Haubmann

## PIOMBINO ALTO PIOMBINO BASSO

---

Thick steel tube, nuts and screws, a tabletop – a PIOMBINO table consists of recurring elements. The legs rise up from the ground, just to turn ninety degrees at the right spot and to hold the top plate. The overlapping silhouettes remind of urban and industrial zones, a harbour, Berlin streets where the ground-water is regulated by enormous systems of tubular steel, where all the geometrical shapes melt together, confusion. Its seven different versions allow versatile application, they fit together, they can stand alone.

PIOMBINO merges into Atelier Haußmanns collection as if it has always been part of it.

---

### **Material**

#### **Table top:**

25 mm thick composite panel covered on both sides with Duropal HPL, M6 screw sockets.  
Art.-Nr. #2415 available with a grey 10 mm Parsol glass plate.

#### **Frame:**

45 mm tubular steel, laser-cut 4 mm steel sheet, galvanized mounting accessories, plastic furniture glides, powder-coating (solvent-free polyester resin) or chrome.

### **Color**

#### **Table top:**

Available in toffee metallic or black mat

#### **Frame:**

Black mat (RAL 9005) or chrome

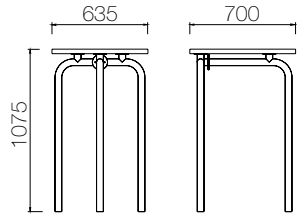

#700.1 PA Black mat/HPL Toffee metallic  
 #700.2 PA Black mat/HPL Black mat

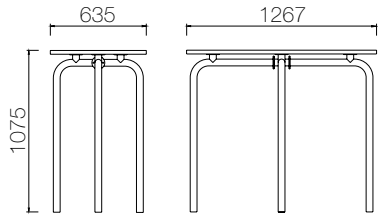
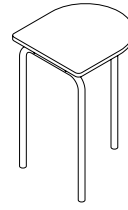

#1267.1 PA Black mat/HPL Toffee metallic  
 #1267.1 PA Black mat/HPL Black mat

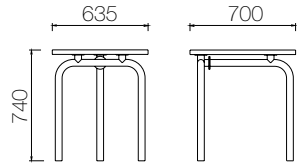
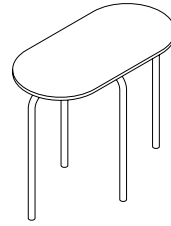

#700.1 PB Black mat/HPL Toffee metallic  
 #700.2 PB Black mat/HPL Black mat

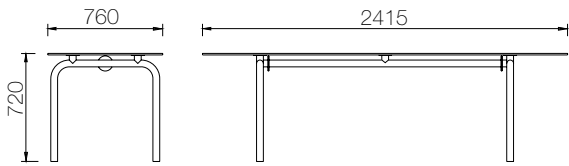
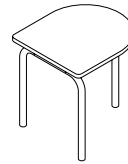

#2415.2 PB\_CR Chrome/Glass

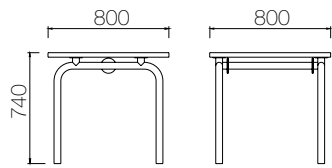
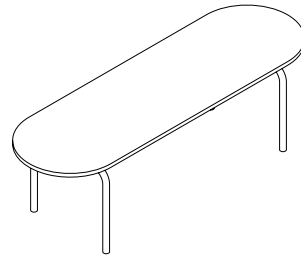

#800.1 PB Black mat/HPL Toffee metallic  
 #800.1 PB Black mat/HPL Black mat

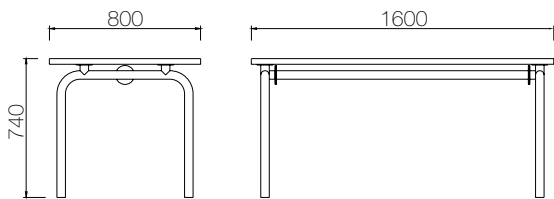
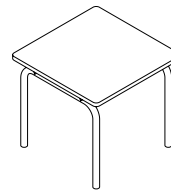

#1600.1 PB Black mat/HPL Toffee metallic  
 #1600.1 PB Black mat/HPL Black mat

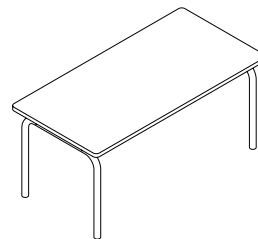



# PIOMBINO ALTO

Bar table  
by Andreas Haußmann



## PIOMBINO ALTO

---

This PIOMBINO ALTO version is three-legged and stands securely even on unplain surfaces. Its table top is curved on one side, the straight sides of two tables can be put together. It offers space for up to three persons.

PIOMBINO tables are a modular system with a simple connection – visually and functionally the heart of the product. They are shipped as a flat-pack and can be set up easily, by putting together first the frame and then adding the tabletop.

---

### **Material**

#### **Table top:**

25 mm thick composite panel covered on both sides with Duropal HPL, M6 screw sockets.

#### **Frame:**

45 mm tubular steel, laser-cutted 4 mm steel sheet, galvanized mounting accessories, plastic furniture glides, powder-coating (solvent-free polyester resin) or chrome.

### **Color**

#### **Table top:**

Available in toffee metallic or black mat

#### **Frame:**

Black mat (RAL 9005) or chrome

### **Size**

H 107,5 x W 63,5 x D 70 cm



# PIOMBINO ALTO

Bar table  
by Andreas Haußmann

## PIOMBINO ALTO

---

The four-legged version of PIOMBINO ALTO has a curved table top on both sides. Its wider top plate offers space for up to four people or a good base as a workstation.

PIOMBINO tables are a modular system with a simple connection – visually and functionally the heart of the product. They are shipped as a flat-pack and can be set up easily, by putting together first the frame and then adding the tabletop.

---

### **Material**

#### **Table top:**

25 mm thick composite panel covered on both sides with Duropal HPL, M6 screw sockets.

#### **Frame:**

45 mm tubular steel, laser-cut 4 mm steel sheet, galvanized mounting accessories, plastic furniture glides, powder-coating (solvent-free polyester resin) or chrome.

### **Color**

#### **Table top:**

Available in toffee metallic or black mat

#### **Frame:**

Black mat (RAL 9005) or chrome

### **Size**

H 107,5 x W 63,5 x D 126,7 cm



# PIOMBINO BASSO

Table  
by Andreas Haußmann

## PIOMBINO BASSO

---

This PIOMBINO BASSO version offers with nearly two and a half meter enough space for various applications. The frame is easily set up just by applying four screws, rubber pads prevent the table top from shifting. The long PIOMBINO BASSO stands out among the other tables of the series, because construction and frame remain visible through the glass.

PIOMBINO tables are a modular system with a simple connection – visually and functionally the heart of the product. They are shipped as a flat-pack and can be set up easily, by putting together first the frame and then adding the tabletop.

---

### **Material**

#### **Table top:**

25 mm thick composite panel covered on both sides with Duropal HPL, M6 screw sockets.  
Available with a grey 10 mm Parsol glass plate.

#### **Frame:**

45 mm tubular steel, laser-cut 4 mm steel sheet, galvanized mounting accessories, plastic furniture glides, powder-coating (solvent-free polyester resin) or chrome.

### **Color**

#### **Table top:**

Available in toffee metallic, black mat or grey glass

#### **Frame:**

Black mat (RAL 9005) or chrome

### **Size**

Glass plate: H 72 x W 76 x D 241,5 cm  
Composite panel: H 73,5 x W 76 x D 241,5 cm



# LÁSZLÓ

Chair  
by Andree Weißert

## LÁSZLÓ

---

Essentially formed from two bent steel tubes, LÁSZLÓ is a pleasingly logical piece of design, one which lets the construction dictate the form, without completely abdicating its responsibility for the functionality: the angle of seat and backrest provide a high degree of sitting comfort, something supported, as it were by the natural buoyancy of the steel tube construction. The stretcher between the sunken front legs neatly allowing for a range of alternative sitting positions.

---

### **Material**

#### **Frame:**

Ø 25 mm steel tube frame, plastic furniture glides (glides for special floors on request), powder-coating (solvent-free polyester resin), rubber washers, screws.

#### **Seat shells:**

Moulded beech-wood, ash-wood finish, black coated.

### **Color**

Black mat (RAL 9005) / Further RAL colors on request

### **Size**

#### **Art.-Nr. #840.1:**

H 84 x W 40 x D 59 cm, 8 kg

Seat area: W 40 x D 41 cm

Seat height: 46 cm

Packed:

H 86 x W 42 x D 61 cm, 9,5 kg

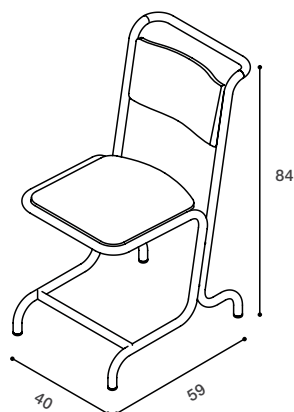



# SPRING

Stool  
by Federic Sonnenberg and  
Lukas Semmler



## SPRING

---

Constructed from steel rods connected to a metal base and wooden seat the SPRING stool is at first a neatly reduced object whose simplicity and clarity makes a very self-confident nod to the early days of American Mid-Century Modernism; and is at second a thoroughly satisfying sitting experience, for the steel rods are spring steel rods and consequently the stool moves, rocks gently with you.

---

**Material**

**Frame:**

Steel 10\*10 mm, spring steel Ø 3,5 mm, PA belt, powder-coating (solvent-free polyester resin).

**Seat shell:**

Hand-turned ash wood, black stained and transparently mat coated.

**Color**

Black mat (RAL 9005)

**Size**

H 48,5 x Ø 33 cm

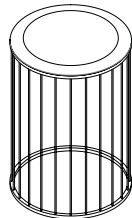



# TISCH LEIPZIG

Table  
by Atelier Haußmann

## TISCH LEIPZIG

---

### **Material**

#### **Frame:**

Bent perforated steel sheet (2 mm thick, 10 mm perforation), steel blanks, felt pads, powder coating (solvent-free polyester resins).

#### **Table top:**

55 mm ash-wood, black mat coated.

### **Color**

#### **Frame:**

Black glossy (9005),  
further RAL colors on request

#### **Table top:**

Black mat, coated various times,  
further colors on request

### **Size**

#### **Art.-Nr. #1400 (incl. Table top):**

H 75,5 x W 140 x D 140 cm

#### **Art.-Nr. #1000 (excl. Table top):**

H 70 x W 61 x D 61 cm

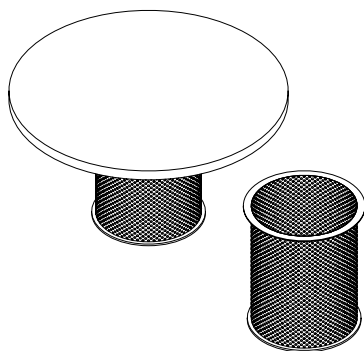



# AFFE

Trestle  
by Thesenfitz & Wedekind

## AFFE

---

A height adjustable trestle made of flat and round steel. It is applicable with several shelves and slabs. Thesenfitz & Wedekind called themselves lucky to find something that perfect in form – something that can only be found, not invented. Atelier Haußmann made the trestle fashionable again by manufacturing it in the traditional way with small Berlin craft producers.

---

**Material** Flat steel (40\*6 mm), steel tube, round steel, lasered flat steel, foam rubber, felt, screws and nuts, special oil for steel.

**Color** Oiled steel

**Size** Available in three sizes:

**Art.-Nr. #390.1:**

H 66 – 97,5 x W 41 x D 39 cm, 14 kg

Depth including rest: 45 cm

Packed:

H 68 x W 43 x D 42 cm, 15,5 kg

**Art.-Nr. #480.1:**

H 66 – 97,5 x W 41 x D 48 cm, 15 kg

Depth including rest: 54 cm

Packed:

H 68 x W 43 x D 50 cm, 16,2 kg

**Art.-Nr. #600.1:**

H 66 – 97,5 x W 41 x D 60 cm, 16 kg

Depth including rest: 66 cm

Packed:

H 68 x W 43 x D 62 cm, 17,5 kg

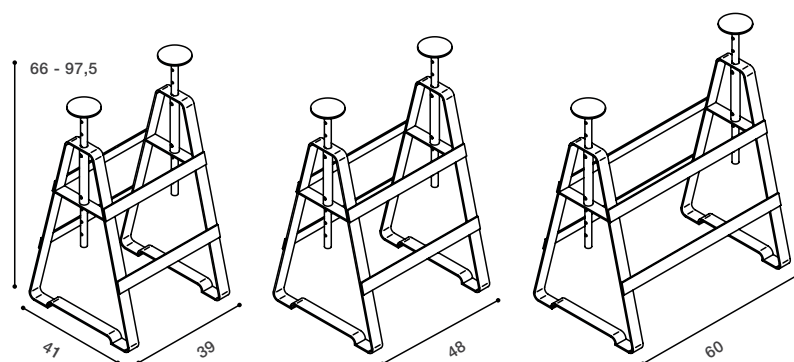



# LACKAFFE

Testle  
by Thesenfitz & Wedekind

# LACKAFFE

---

A height adjustable trestle made of flat and round steel. It is applicable with several shelves and slabs. The powder-coated LACKAFFE plays with the image of solid steel furniture. Thesenfitz & Wedekind called themselves lucky to find something that perfect in form – something that can only be found, not invented. Atelier Haußmann made the trestle fashionable again by manufacturing it in the traditional way with small Berlin craft producers.

---

**Material** Flat steel (40\*6 mm), steel tube, round steel, lasered flat steel, foam rubber, felt, screws and nuts, powder coating (solvent-free polyester resins).

**Color** Black glossy or mat (RAL 9005)  
White glossy or mat (RAL 9016)  
Sulfur yellow glossy (RAL 1016)

Further RAL colors on request

**Size** Available in three sizes:

**Art.-Nr. #390.1:**

H 66 – 97,5 x W 41 x D 39 cm, 14 kg

Depth including rest: 45 cm

Packed:

H 68 x W 43 x D 42 cm, 15,5 kg

**Art.-Nr. #480.1:**

H 66 – 97,5 x W 41 x D 48 cm, 15 kg

Depth including rest: 54 cm

Packed:

H 68 x W 43 x D 50 cm, 16,2 kg

**Art.-Nr. #600.1:**

H 66 – 97,5 x B 41 x T 60 cm, 16 kg

Depth including rest: 66 cm

Packed:

H 68 x W 43 x D 62 cm, 17,5 kg

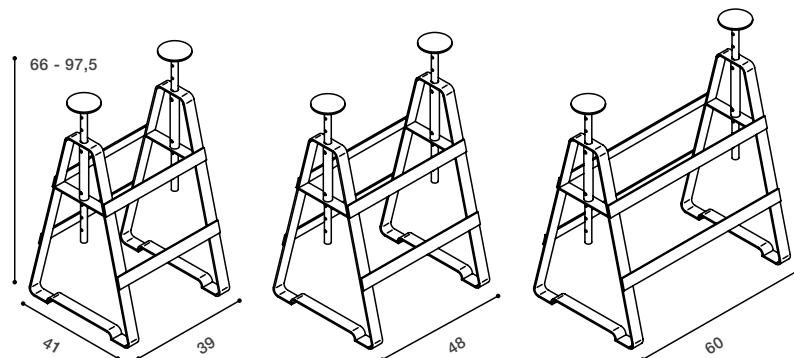



# BOLOGNA

Table  
by Atelier Haußmann



## BOLOGNA

---

### **Material**

#### **Frame:**

Steel tube Ø 42,4\*2,5 mm, PE furniture glides, galvanized mounting accessories, powder-coating (solvent-free polyester resin).

#### **Table top:**

MDF-plate, linoleum on both sides.

### **Color**

Various color combinations of frame color (according to RAL) and linoleum possible.

### **Size**

Two different sizes available:

#### **Art.-Nr. #120.1:**

H 74,2 X W 120 X D 150 cm

#### **Art.-Nr. #090.1:**

H 74,2 X W 90 X D 110 cm

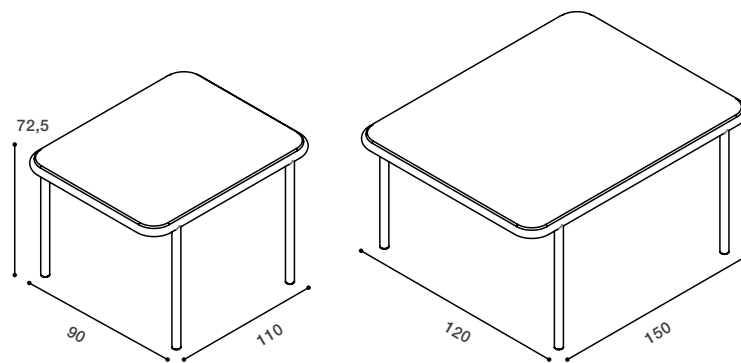



## PETITE TABLE D'ANGLE

Side table  
by Hervé Humbert

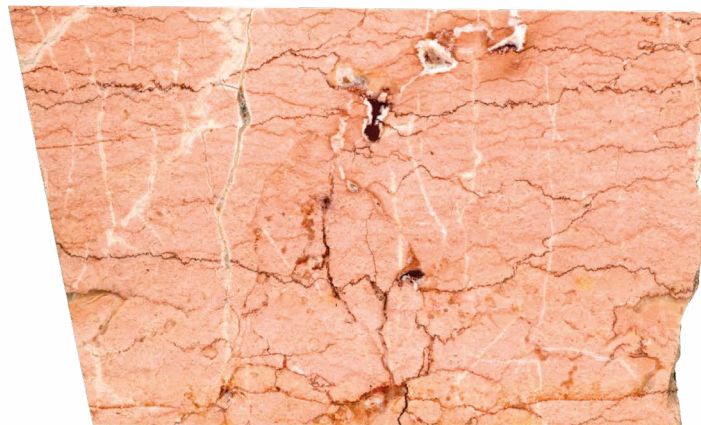

Stones (clockwise):

Nr. 20 Rosa Portogallo (Portugal), Nr. 17 Verde  
Maritaca (Brasil), Nr. 11 Rosa Portogallo (Portugal)

## PETITE TABLE D'ANGLE

---

"PETITE TABLE D'ANGLE" is an unusual table object in which Humbert blurs the boundaries between art and design. The series developed for Atelier Haußmann is comprised of 31 unique objects each consisting of a remnant marble slab with a breakpoint, surrounded by a steel angle frame which has been individually composed to match the random shape of the slabs, yet remaining open at the breakpoint. Unexpected perspectives occur as a result of this tabletop, which juts out like a cliff hanging over the frame and the arrangement of the table legs is reminiscent of architectural structures.

The "small corner table" is a game of confronting common habits of seeing. In this first pursuit of Humbert to create purely an object of design, he follows the same approach as he does in his art works. He does not look for suitable forms for an industrial implementation of his idea, he devotes himself to the material instead. The result, a sculpture which functions as a piece of furniture.

Issues of sustainability concerning the reuse of the marble slabs deemed useless for conventional use, are just as much integrated in "PETITE TABLE D'ANGLE" as the traces on the materials which bear witness of the extraction and further manufacturing processes, because they remain, just like the different grains suggesting the country of origin, as an image and a history. The value of the marble now is measured in terms of its visually palpable story that may not be polished away. The marble relic turns into a piece of Land Art bestowed with a suitable form of representation.

---

**Material** Frame made of steel (L-profile 25 x 25\*3 mm), powder-coating (solvent-free polyester resin), marble slab, rubber spacers, brass plate.

**Color** White mat (RAL 9016)

**Edition** Limited and numbered,  
first edition: 31 pieces

**Size** Width and depth depend on the marble slab,  
height 30/35 cm.

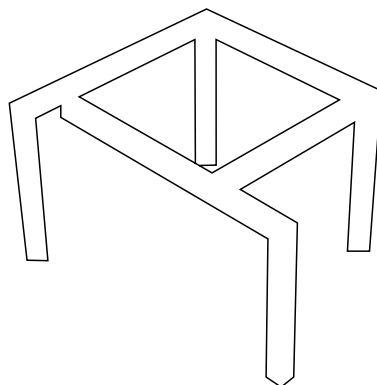



# BLUMENAMPEL & BLUMENKUGEL

Object  
by Zascho Petkow

Object  
by Andreas Haußmann  
& Zascho Petkow

## BLUMENAMPEL

---

In its standard version BLUMENAMPEL comes with a plastic vase (PVC) and is thus perfectly suited for use as a hanging basket "room object". Blumenampel exudes a certain Victorian, pre-industrial romantic that is typical of much of Atelier Haußmanns furnitures.

---

**Material** Ø 22 mm steel tube, powder-coating (solvent-free polyester resin), PVC vase, PP rope, hook, dowel.

**Color** Black mat (RAL 9005)

**Size** **Art.-Nr. #200.1:**  
H 109 x Ø 17,5 cm, 4,5 kg  
Packed:  
H 112 x W 20 x D 20 cm, 5 kg  
Vase: H 21 x Ø 17,6 cm

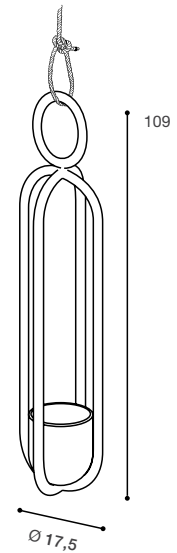

## BLUMENKUGEL

---

**Material** Ø 22 mm steel tube, powder-coating (solvent-free polyester resin), PVC vase, PP rope, hook, dowel.

**Color** Black mat (RAL 9005)

**Size** **Art.-Nr. #250.1:**  
H 76 x W 47 x D 29 cm, 3,8 kg  
Packed:  
H 75 x W 42 x D 42 cm, 5,3 kg  
Vase: H 13 x Ø 24,6 cm

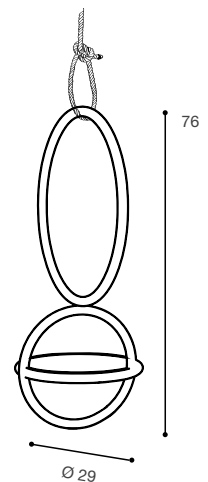



# BLUMENAMPEL & BLUMENKUGEL

## Edition

Object  
by Zascho Petkow  
"Ashes II" vase by Birgit Severin

Object  
by Andreas Haußmann & Zascho Petkow,  
"Jar" vase by Birgit Severin

## BLUMENAMPEL EDITION

---

BLUMENAMPEL EDITION comes with a rubber vase handmade by Birgit Severin. Both designers, Zascho Petkow and Birgit Severin, developed their projects (BLUMENAMPEL and the ASHES series) independently from each other.

BLUMENAMPEL EDITION combines the newest production techniques with handcraft. A novel type of materiality was developed through combining 3-D printing with rubber rotation casting, resulting in a rough, mat surface, covered with a sparkling pattern of jewel-like points.

---

**Material** Ø 22 mm steel tube, powder-coating (solvent-free polyester resin), rubber vase, PP rope, hook, dowel.

**Color** Black mat (RAL 9005)

**Size** **Art.-Nr. #200.1:**  
H 109 x Ø 17,5 cm, 4,5 kg  
Packed:  
H 112 x W 20 x D 20 cm, 5 kg

**Vase "Ashes":**  
H 24 x Ø 17,5 cm

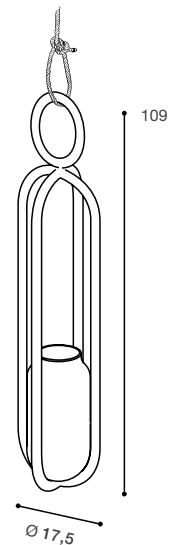

## BLUMENKUGEL EDITION

---

**Material** Ø 22 mm steel tube, powder-coating (solvent-free polyester resin), rubber vase, PP rope, hook, dowel.

**Color** Black mat (RAL 9005)

**Size** **Art.-Nr. #250.1:**  
H 76 x W 47 x D 29 cm, 3,8 kg  
Packed:  
H 75 x W 42 x D 42 cm, 5,3 kg

**Vase "Jar":**  
H 15 x Ø 24,6 cm

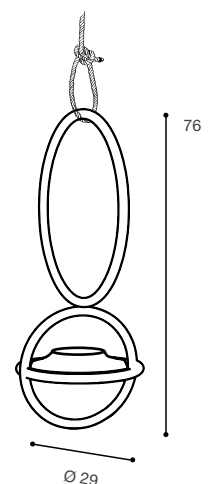





# RING

Wardrobe / Wall object  
by Zascho Petkow

## RING

---

**Material** Flat steel 20\*10 mm, 20\*5 mm,  
turned metal parts, plastic washers, powder-coating  
(solvent-free polyester resin) / chromed (CR) / copperplated (K).

**Color** Copperplated (K)  
Chromeplated (CR)  
Powder-coated (RAL colors)

**Size** Three different diameters available:  
**Art.-Nr. #400.1, #400.CR, #400.K :**  
Ø 40 cm, 2,2 kg  
Packed:  
H 5 x W 45 x D 45 cm, 3,2 kg  
**Art.-Nr. #750.1, #750.CR, #750.K :**  
Ø 75 cm, 4,2 kg  
Packed:  
H 5 x W 80 x D 80 cm, 5,7 kg  
**Art.-Nr. #900.1, #900.CR, #900.K :**  
Ø 90 cm, 5 kg  
Packed:  
H 5 x W 95 x D 95 cm, 7 kg

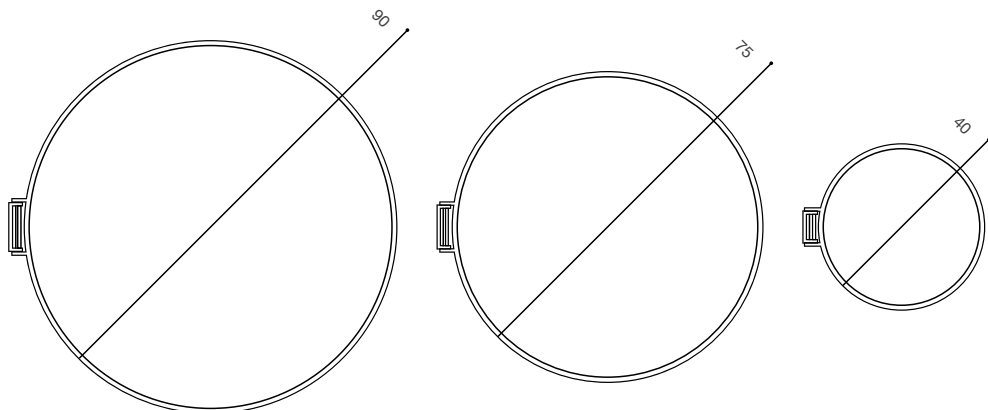



# YOUTOO

Wardrobe  
by Atelier Haußmann

## YOUTOO

---

The design of all the collections products is shaped by the idea to create new products with basic production processes and traditional functions, not matching and not being depending on current fashions or trends. This concept includes the wardrobe YOUTOO.

YOUTOO cited and gives a hint to well known designs and materials, interprets them new.

---

**Material** Ø 25 mm steel tube, flat steel, powder-coating (solvent-free polyester resin), PE furniture glides, hooks made out of flat steel.

**Color** Black mat (RAL 9005), grey beige mat (RAL 1019)

**Size** **Art.-Nr. #110.1, #110.2:**  
H 182 x W 70,5 x D 48 cm, 15,5 kg  
Packed:  
H 185 x W 72 x D 49,5 cm, 18,5 kg

Hooks available with a length of:  
12 cm (**Art.-Nr. #111.1, #112.1**)  
22,5 cm (**Art.-Nr. #111.2, #112.2**)

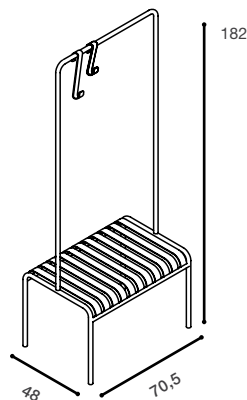



# HELLOGOODBYE

Wardrobe  
by Atelier Haußmann

## HELLOGOODBYE

---

The coat rack HELLOGOODBYE is made of a flat piece crude steel and six round hooks with notches to prevent clothes or coat hangers from sliding off. The steel version is treated with a special oil for rust-protection. Three stainless steel screws are included for wall mounting. The white version is primed and powder-coated.

---

**Material** Flat steel 5 mm, round steel (Ø 12 mm, length 100 mm), oil or powder-coating (solvent-free polyester resin), dowel, screws, 25 Torx-bit.

**Color** Oiled raw steel or white glossy powder-coating (RAL 9016)

**Size** **Art.-Nr. 108,1, #108,2:**  
H 8 x W 108 x D 10,5 cm, 4,1 kg  
Packed:  
H 9 x W 110 x D 13 cm, 5,3 kg

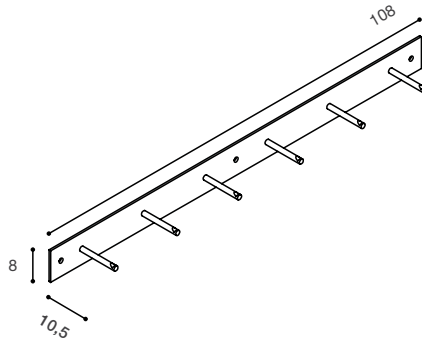



# POGGIBONSI

Shelf  
by Atelier Haußmann

## POGGIBONSI

---

Poggibonsi does not take up much room and organizes your storage on one level. Ideal for all those dear and indispensable things to be clearly arranged and within easy reach. It is made of 2 mm steel and is very robust despite its delicate appearance.

---

**Material** 2 mm steel, powder-coating (solvent-free polyester resin), plastic spacers, stainless steel screws, stainless steel washers.

**Color** Black mat (RAL 9005), white mat (RAL 9016) or grey beige mat (RAL 1019) powder-coated.

**Size** Two different sizes available:  
**Art.-Nr. #055.9016:**  
H 11,5 x W 55 x D 29 cm, 5 kg  
Packed:  
H 15 x W 58 x D 32 cm, 5,3 kg  
**Art.-Nr. #100.9016:**  
H 11,5 x W 100 x D 19 cm, 6,2 kg  
Packed:  
H 15 x W 103 x D 22 cm, 6,5 kg

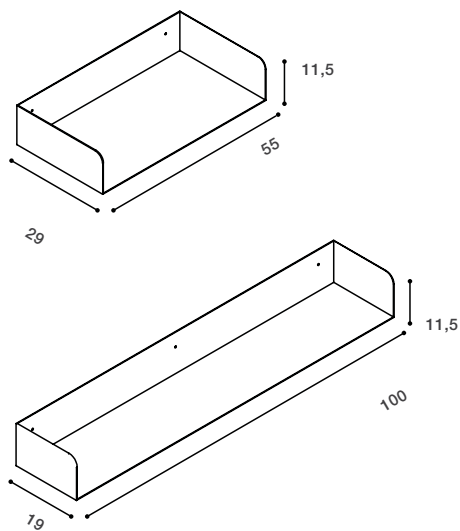





## 2 PM DAYBED

Daybed  
by Atelier Haußmann

## 2 PM DAYBED

---

### **Material**

#### **Frame:**

Ø 30 mm steel tube, perforated steel sheet, powder-coating (solvent-free polyester resins), brass glides (furniture glides for special floors on request)

#### **Mattress:**

Fabric cover made of 70% new wool, 30% flax, coconut fiber mattress.

### **Color**

Black mat powder-coated (RAL 9005), anthracite-colored cover. Other combinations on request.

### **Size**

#### **Art.-Nr.: #010.1**

H 40 x W 86 x D 196 cm, 29,5 kg

Lying surface: W 80 x D 190 cm

Packed:

H 44 x W 88 x D 198 cm, 33 kg

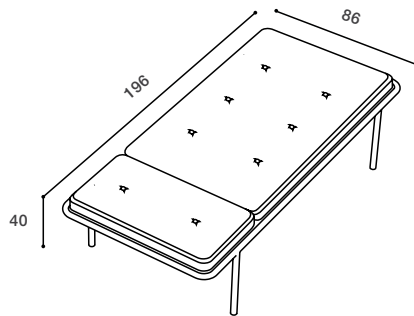



# SEVENFEETUP

Bed  
by Atelier Haußmann

## SEVENFEETUP

---

- Material** Steel tube frame Ø 27 mm. MDF-plate 19 mm with milled openings, powder-coating (solvent-free polyester resins).  
Made to order.
- Color** Frame color freely selectable according to RAL, MDF board in white or black.
- Edition** Limited to 50 pieces
- Size** Two different widths available:  
**Art.-Nr.: #001.1**  
H 122 X W 152 X D 209 cm  
Lying surface: W 140 X D 200 cm  
**Art.-Nr.: #001.2**  
H 122 X W 172 X D 209 cm  
Lying surface: W 160 X D 200 cm

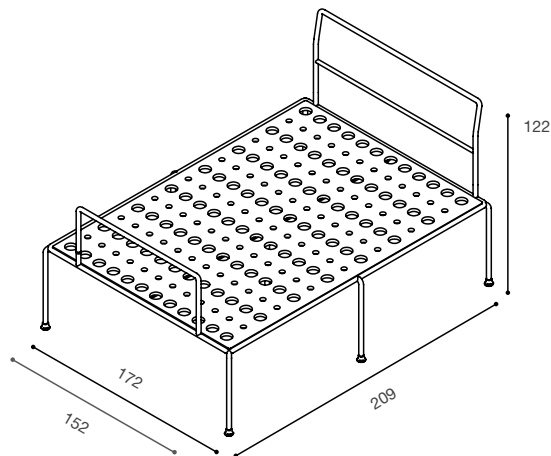

## **Atelier Haußmann**

Wilhelminenhofstr. 92  
12459 Berlin, Germany  
[post@atelierhausmann.de](mailto:post@atelierhausmann.de)  
[www.atelierhausmann.de](http://www.atelierhausmann.de)

©Atelier Haußmann, 2020